

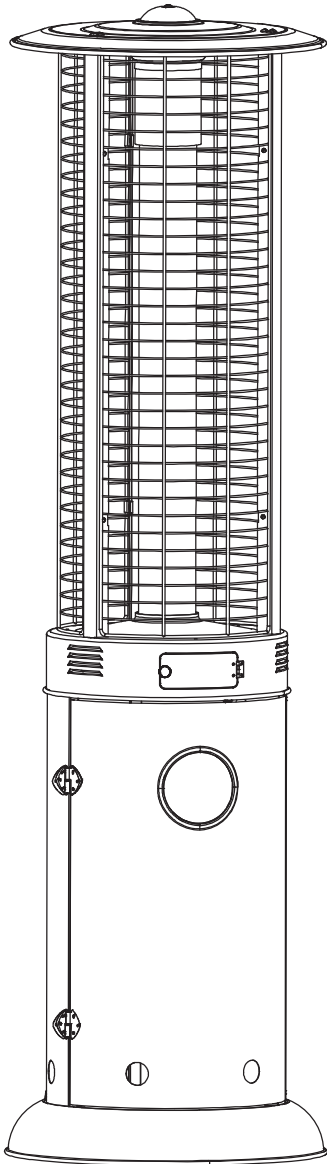

# ONYX GLASS TUBE PATIO HEATER

Item # 9185

Model # KLD7003SA



## DANGER

FOR YOUR SAFETY:

If you smell gas:

1. Shut off gas to the appliance.
2. Extinguish any open flame.
3. If odor continues, keep away from the appliance and immediately call your gas supplier or fire department.

## WARNING

Do not store or use gasoline or other flammable vapors and liquids in the vicinity of this or any other appliance. An LP-cylinder not connected for use shall not be stored in the vicinity of this or any other appliance.

## DANGER

DANGER indicates an imminently hazardous situation which, if not avoided, will result in death or serious injury.

## WARNING

Improper installation, adjustment, alteration, service or maintenance can cause property damage, injury or death. Read the installation, operation and maintenance instructions thoroughly before installing or servicing this equipment.

## DANGER

Failure to comply with the precautions and instructions provided with this heater can result in death, serious bodily injury and property loss or damage from hazards of fire, explosion, burn, asphyxiation, and/or carbon monoxide poisoning. Only persons who can understand and follow the instructions should use or service this heater.

## WARNING

FOR OUTDOOR USE ONLY!

## WARNING

This product can expose you to chemicals including Lead, Chromium (hexavalent compounds), Di(2-ethylhexyl) phthalate (DEHP) and Diisononyl phthalate (DINP), which are known to the State of California to cause cancer and birth defects or other reproductive harm. For more information, go to [www.P65Warnings.ca.gov](http://www.P65Warnings.ca.gov).



## ATTACH YOUR RECEIPT HERE

Keep a copy of your proof of purchase or order confirmation which will be needed if you need to contact us about warranty coverage.

Serial No. \_\_\_\_\_

Purchase Date \_\_\_\_\_



This manual contains important information about the assembly, operation and maintenance of this patio heater. General safety information is presented in the first few pages and is also located throughout this manual. Keep this manual for future reference and to educate new users of this appliance. This manual should be read in conjunction with the labeling on the appliance. Safety precautions are essential when any mechanical or propane-fueled equipment is involved. These precautions are necessary when using, storing, and servicing. Using this appliance with the respect and caution demanded will reduce the possibilities of personal injury or property damage. The symbols shown on page 3 are used extensively throughout this manual. Always heed these precautions, as they are essential when using any mechanical or propane-fueled equipment.

 **DANGER**

**EXPLOSION—FIRE HAZARD**

- Keep solid combustibles, such as building materials, paper, or cardboard a safe distance away from the heater as recommended by the instructions.
- Provide adequate clearances around air openings into the combustion chamber.
- Never use the heater in spaces which do or may contain volatile or airborne combustibles, or products such as gasoline, solvents, paint thinner, dust particles, or unknown chemicals.
- During operation, this appliance can be a source of ignition. Keep heater area clear and free from combustible materials, gasoline, paint thinner, cleaning solvents and other flammable vapors and liquids. Do not use heater in areas with high dust content. Minimum heater clearances from combustible materials: 3 feet/36 inches from top and 2 feet/24 inches from sides.
- Never store propane near high heat, open flames, pilot lights, direct sunlight, other ignition sources, or where temperatures exceed 120° F (49° C).
- Propane vapors are heavier than air and can accumulate in low places. If you smell gas, leave the area immediately.
- Never install or remove a propane cylinder while the heater is lighted, near flame, pilot lights, or other ignition sources or while heater is hot to the touch.
- This heater is red hot during use and can ignite flammables too close to the burner. keep flammables at least 3 feet/36 inches) from top and 2 feet/24 inches from sides. keep gasoline and other flammable liquids and vapors well away from heater.
- Store the propane cylinder outdoors in a well-ventilated space out of the reach of children. Never store the propane cylinder in an enclosed area (house, garage, etc.). If heater is to be stored indoors, disconnect the propane cylinder for outdoor storage.

 **WARNING:**  
**FOR OUTDOOR USE ONLY**

 **CARBON MONOXIDE HAZARD**

This appliance can produce carbon monoxide which has no odor. Using it in an enclosed space can kill you. Never use this appliance in an enclosed space such as a camper, tent or home.

 **DANGER**

**CARBON MONOXIDE HAZARD**

- This heater is a combustion appliance. All combustion appliances produce carbon monoxide (CO) during the combustion process. This product is designed to produce extremely minute, non-hazardous amounts of CO if used and maintained in accordance with all warnings and instructions. Do not block the air flow into or out of the heater.
- Carbon Monoxide (CO) poisoning produces flu-like symptoms, water eyes, headaches, dizziness, fatigue, and possibly death. You can't see and you can't smell it. It is an invisible killer. If these symptoms are present during operation of this product, get fresh air immediately!
- For outdoor use only.
- Never use inside house or other unventilated or enclosed areas.
- This heater consumes air (oxygen). Do not use in unventilated or enclosed areas to avoid endangering your life.

 **WARNING**

**BURN HAZARD**

- Never leave heater unattended when hot or in use.
- Keep out of reach of children.

 **WARNING**

WARNING indicates an imminently hazardous situation which, if not avoided, will result in death or serious injury.

 **WARNING**

Certain materials or items, when stored under the heater, will be subject to radiant heat and could be seriously damaged.

 **CAUTION**

CAUTION indicates an imminently hazardous situation which, if not avoided, may result in minor or moderate personal injury, or property damage.

 **CAUTION**

**SERVICE SAFETY**

- Keep all connections and fittings clean. Make sure propane cylinder valve outlet is clean.
- During set up, check all connections and fittings for leaks using soapy water, never use a flame to check for leaks.
- Use as a heating appliance only. Never alter in any way to use with any device.

 **WARNING**

- This product is fueled by propane gas. Propane gas is invisible, odorless, and flammable. An odorant is normally added to help detect leaks and can be described as having a "rotten egg" smell. The odorant can fade over time so leaking gas is not always detectable by smell alone.
- Propane gas is heavier than air and leaking propane will sink to the lowest level possible. It can ignite by ignition sources including matches, lighters, sparks or open flames of any kind many feet away from the original leak. Use only propane gas set up for vapor withdrawal.
- Store and use propane gas in compliance with local ordinances and codes or with ANSI/NFPA 58. Always turn off propane when not in use.
- Alert children and adults to the hazards of high surface temperatures. Stay away from these surfaces to avoid burning skin or igniting clothing.
- Carefully supervise young children when in the vicinity of the heater.
- Do not hang clothing or any other flammable materials from the heater, or place near the heater.
- Replace any guard or protective device removed for servicing the appliance prior to placing back in service.
- Installation and repair should be done by a qualified service person. The heater should be inspected before each use, and annually by a qualified service person. More frequent cleaning may be required as necessary. It is imperative that the control compartment, burners, and circulating air passageway of the appliance be kept clean.

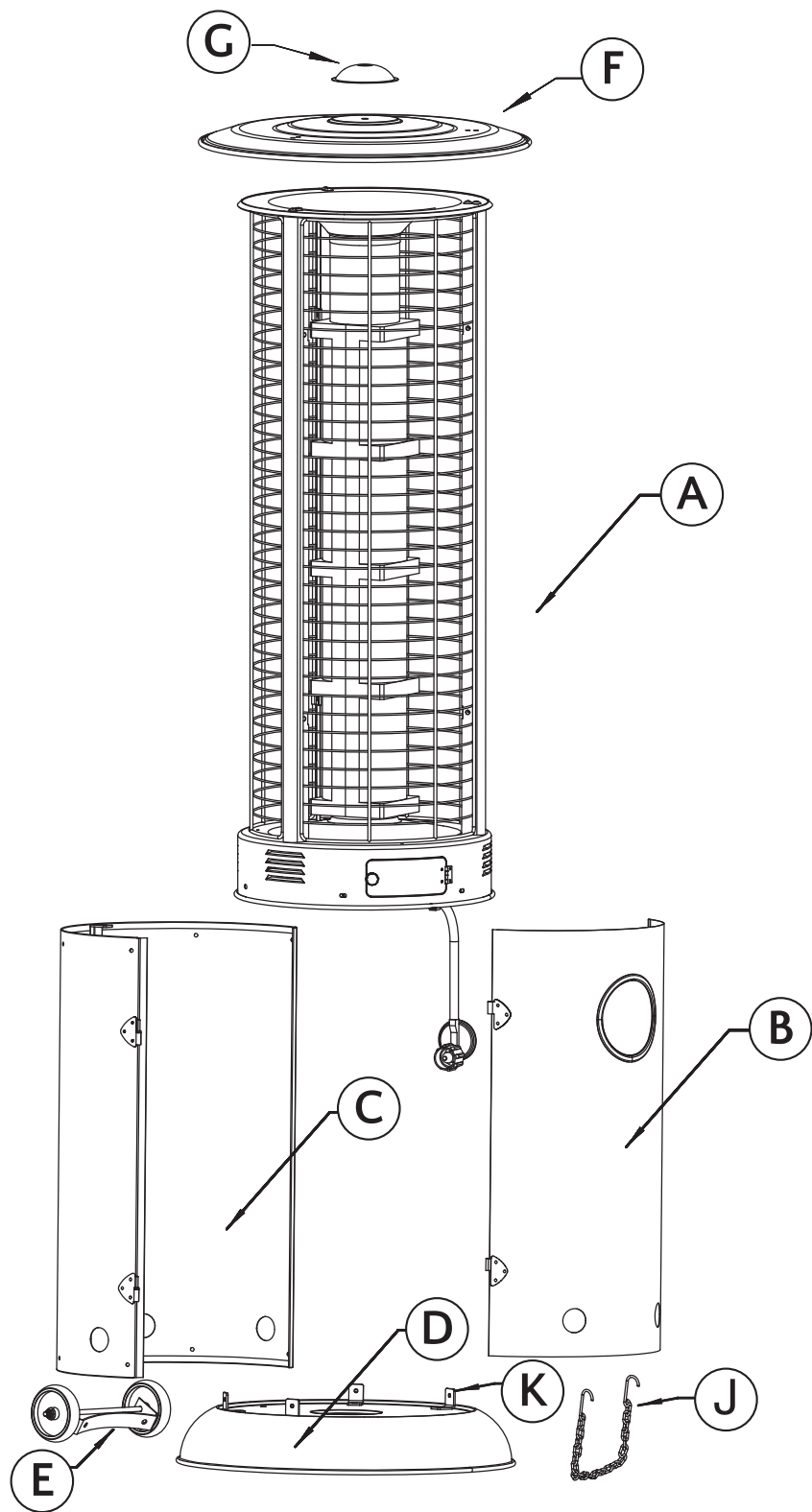

AA	BB	CC	DD
M6*12	M6	M8	M8*16
20PCS	1PCS	2PCS	2PCS

EE	FF	GG
M6*35	M6*12 Preassembled	M5*10 Preassembled
1PCS	6PCS	12PCS



### ALSO REQUIRED



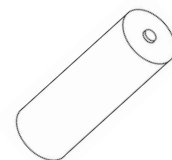





(included)

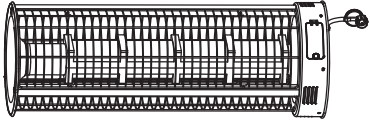
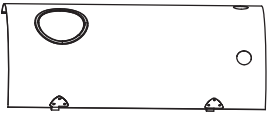
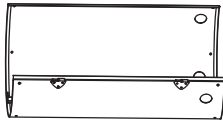

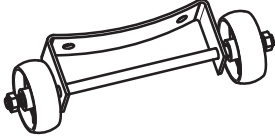
AA Battery

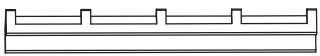
NOTE: to install, unscrew igniter button.

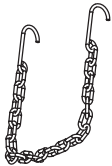
## Part list

Part No	Description	Photo	Qty
A	BURNER UNIT		1 pc
B	DOOR		1 pc
C	BACK PLATE		1 pc
D	BOTTOM		1 pc
E	WHEELS		1 pc
F	REFLECTOR		1 pc
G	UP COVER		1 pc
H	FOAM		1 set
I	GRID PLATE		12pcs
J	CHAIN		1pc
K	CONNETING PLATE		10pcs



## PREPARATION

Before beginning assembly of this appliance, make sure all parts are present. Compare all parts with package contents list and hardware contents as listed on page 4 of this manual. If any part is missing or damaged, do not attempt to assemble this product. Contact customer service for replacement parts.

**ESTIMATED ASSEMBLY TIME:** 60 minutes

### Tools Required for Assembly (NOT included):

- Phillips screwdriver w/medium blade
- Adjustable crescent wrench

**1** Attach Wheels (E) to the Bottom (D) with 2pcs M8x16 (DD) Bolts and M8 (CC) Nuts.



**Hardware Used:** M8x 16



**Hardware Used:** M8

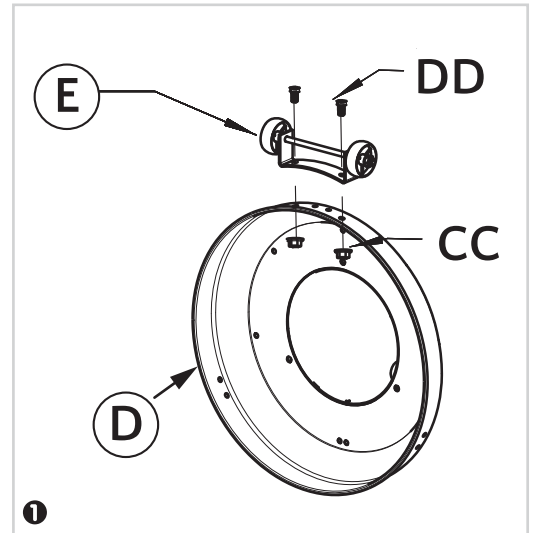

**2** Attach Connecting Plate (K) to the Back Plate(C ) with 10pcs M6x12 (AA) Bolts.  
Make sure the bolts go through the round hole with thread of Connecting plate .



**Hardware Used:** M6x12

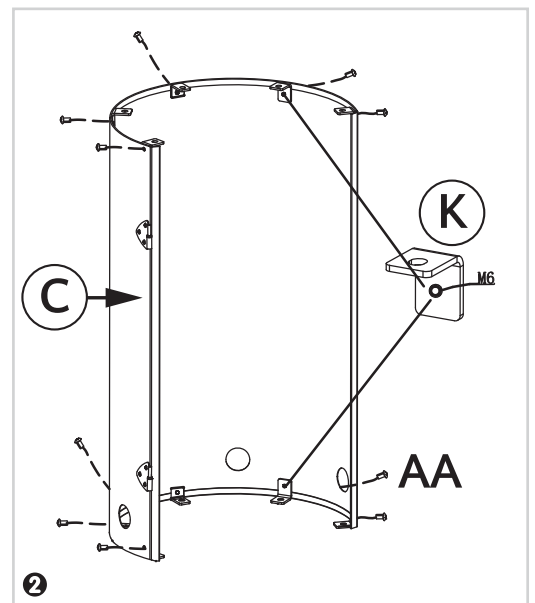

**3** Attach the Back Plate (C) with Bottom (D) with 5pcs M6x12 (AA) Bolts.



Hardware Used: M6x12

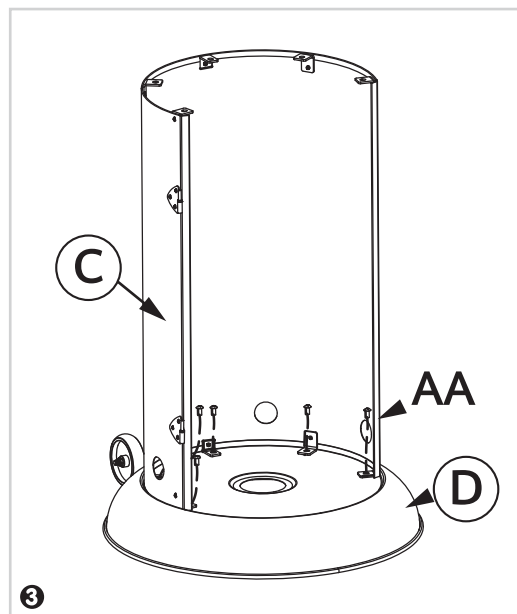

**4** Put the Burner unit (A) onto the Back plate (C), fix it with 5pcs M6x12 (AA) Bolts.



Hardware Used: M6x12

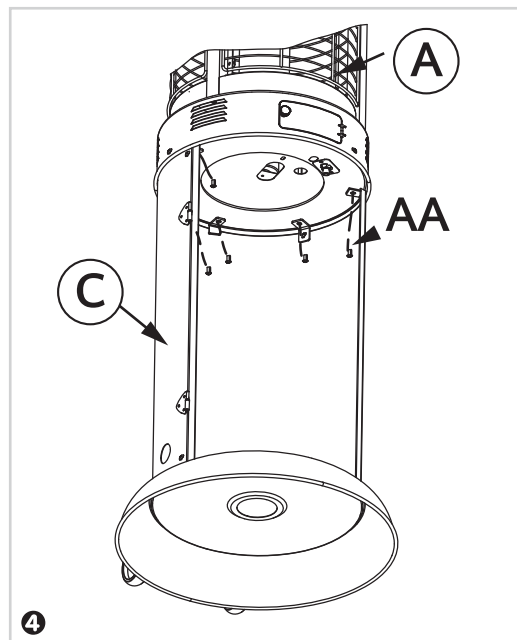

**5** Attach the Door (B) to the Back plate (C). Hook the Chain (J) into the holes of Back plate (C).

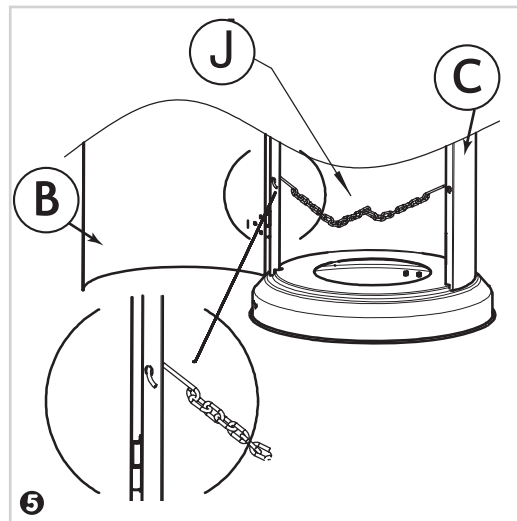

**6** Attach the Up Cover (G) onto the Reflector (F) with 1pc M6x35 (EE) screw and M6 (BB) nut.



Hardware Used: M6



Hardware Used: M6x35

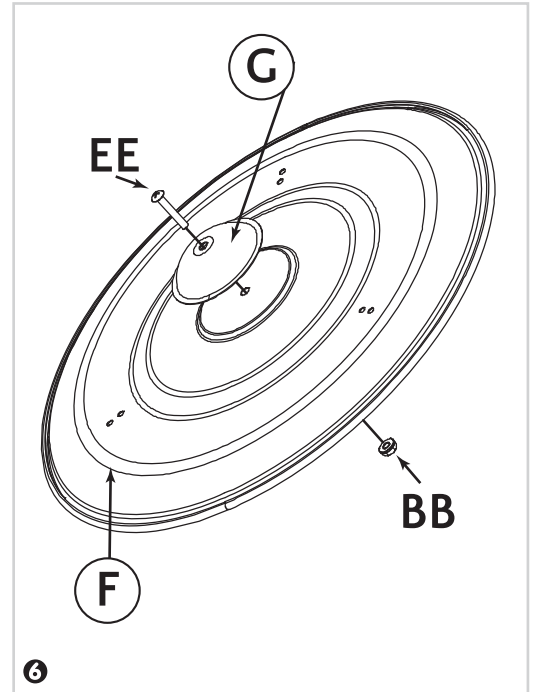

**7** Unscrew the 6pcs preassembled M6x12 (FF) screws, attach the reflector onto the top, then fix them with M6x12 screws.



Hardware Used: M6x12

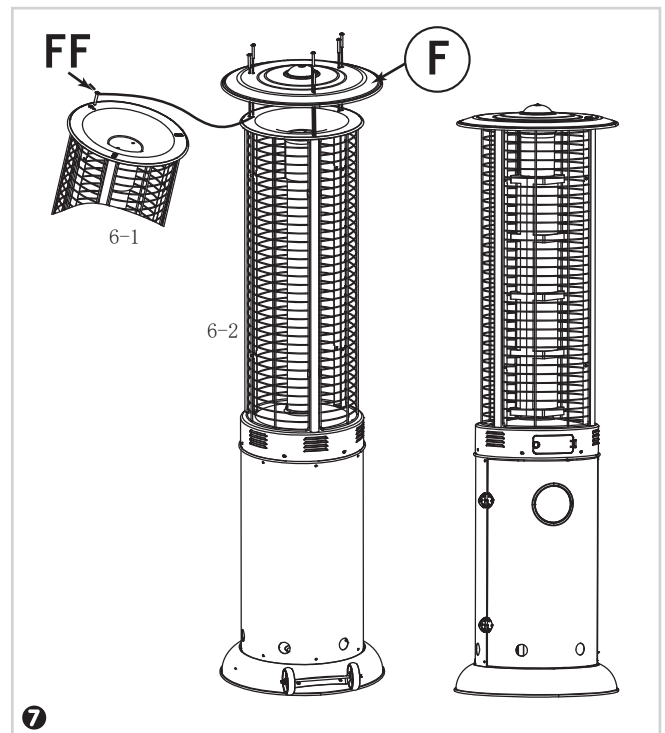



**8** Unscrew from the grid plate (I) the 4pcs M5x10 (GG) screws, disassemble 1 pc protection guard. Remove the protection Foam (H).



Hardware Used: M5x10

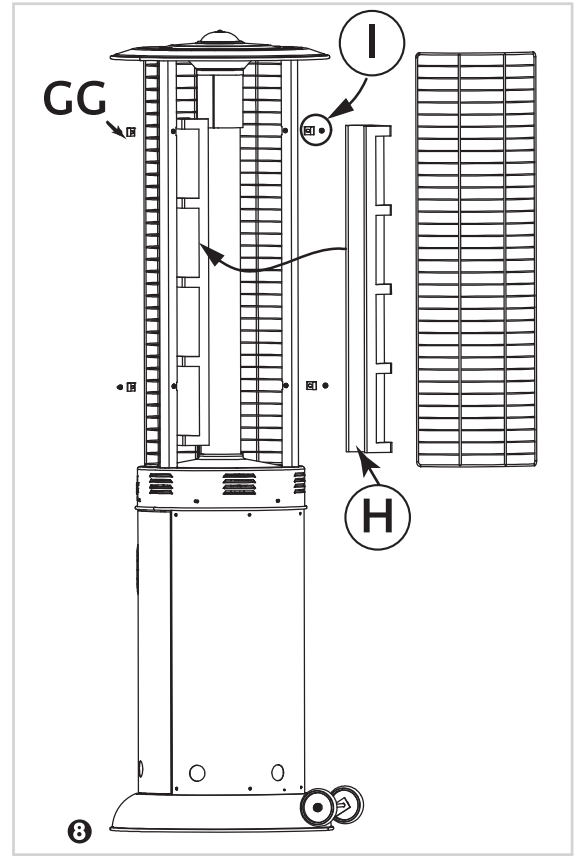

**9** Attach the protection guard back with grid plate (I) 4pcs M5x10 (GG). Complete.



Hardware Used: M5x10

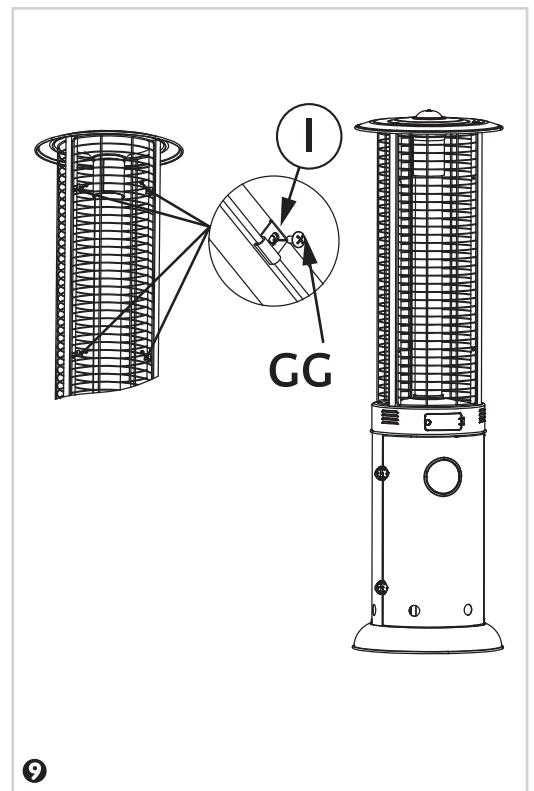

**10** When installing an LPG cylinder, it may be easier to remove the Door Panel completely and set aside. Place the cylinder on the **Bottom Plate**. Secure using the horizontal **Bolts** in the vertical side of each **Tank Bracket** to prevent the cylinder from shifting. Connect the gas hose to 20lb LPG cylinder (not included). Screw the regulator to the cylinder. Tighten securely.

*NOTE: The regulator with gas hose is supplied.*

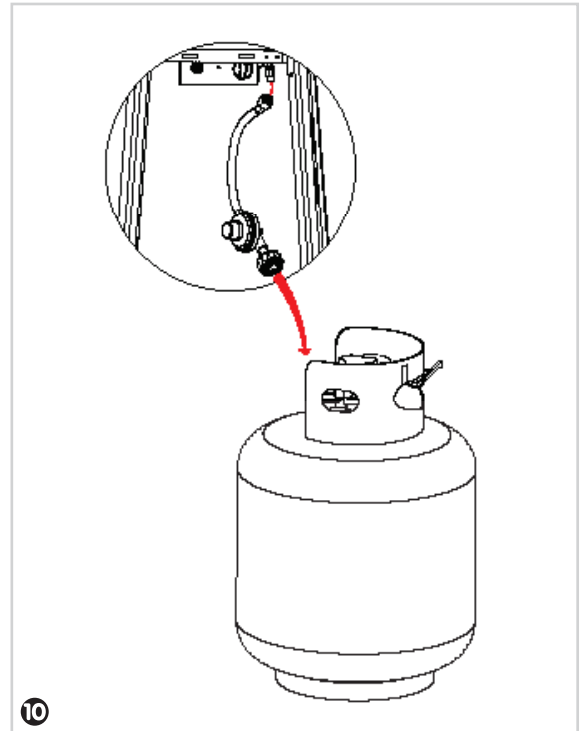

## REPLACEMENT GLASS TUBE

Unscrew from the grid plate (I) the 4 pcs M5x10 (GG) screws, disassemble 1pc protection guard. Unscrew the 6pcs preassembled M6x12 (FF) screws, take out the top and replace the glass tube carefully.

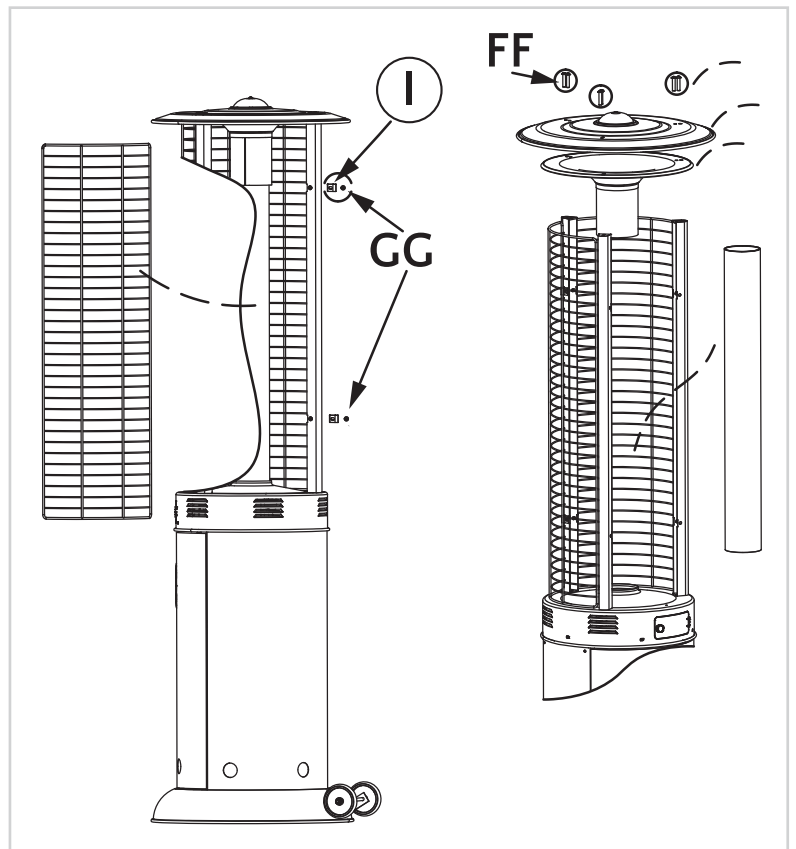

# OPERATING INSTRUCTIONS

## LEAK TEST

1. Make 2–3 oz. of leak test solution (one part liquid dish washing detergent and three parts water).
2. Apply several drops of solution where hose attaches to regulator.
3. Apply several drops of solution where regulator connects to cylinder.
4. Make sure all patio heater valves are OFF.
5. Turn cylinder valve ON.



### WARNING

- Perform all leak tests outdoors.
- Extinguish all open flames.
- NEVER leak test when smoking
- Do not use heater until all connections have been leak tested and show no signs of leakage.

## IF BUBBLES APPEAR AT ANY CONNECTION, THERE IS A LEAK.

1. Turn cylinder valve OFF.
2. If leak is detected at hose/regulator connection, tighten connection and perform another leak test. If bubbles continue to appear, call our customer service hotline at **877-387-3639**.
3. If leak is detected at regulator/cylinder valve connection, disconnect, reconnect, and perform another leak test. If you continue to see bubbles after several attempts, cylinder valve is defective. Call our customer service hotline at **877-387-3639**.

## IF NO BUBBLES APPEAR AT ANY CONNECTION, THE CONNECTIONS ARE SECURE.

**Note:** Whenever gas connections are loosened or removed, you must perform a complete leak test.



### WARNING: FOR OUTDOOR USE ONLY



### CARBON MONOXIDE HAZARD

This appliance can produce carbon monoxide which has no odor. Using it in an enclosed space can kill you. Never use this appliance in an enclosed space such as a camper, tent or home.

**Caution:** Do not attempt to operate this appliance until you have read and understand all Safety Information in this manual and all assembly is complete and leak tests have been performed.

## BEFORE TURNING GAS SUPPLY ON:

1. Your heater was designed and approved for **OUTDOOR use only**. Do NOT use it inside a building, garage, or any other enclosed area.
2. Make sure surrounding areas are free of combustible materials, gasoline, and other flammable vapors or liquids.
3. Ensure that there is no obstruction to air ventilation. Be sure all gas connections are tight and there are no leaks.
4. Be sure the cylinder cover is clear of debris. Be sure any component removed during assembly or servicing is replaced and fastened prior to starting.

## BEFORE LIGHTING:

1. Heater should be thoroughly inspected before each use, and by a qualified service person at least annually. If re-lighting a hot heater, always wait at least 5 minutes.
2. Inspect the hose assembly for evidence of excessive abrasion, cuts, or wear. Suspected areas should be leak tested. If the hose leaks, replace it prior to operation. Only use the replacement hose assembly specified by the manufacturer.

# OPERATING INSTRUCTIONS

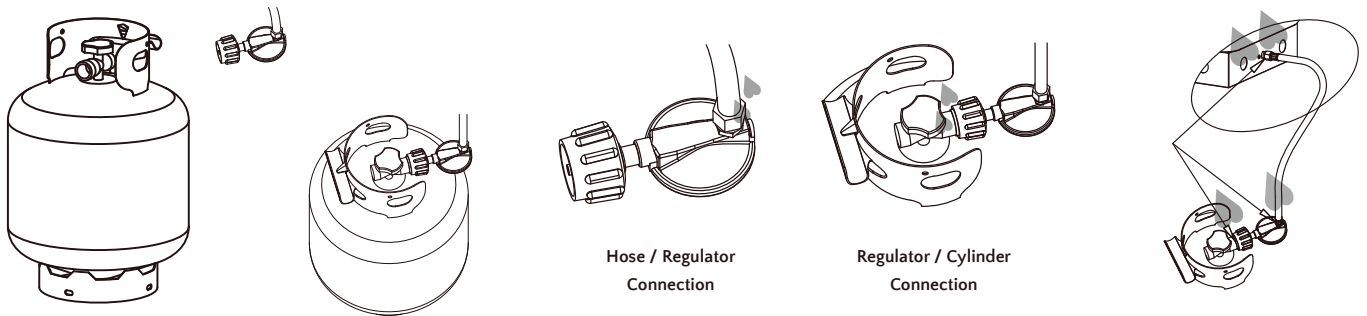

A minimum supply pressure of .5 psi is required for the purpose of input adjustment of propane gas. Storage of an appliance indoors is permissible only if the cylinder is disconnected and removed from the appliance. A cylinder must be stored outdoors in a well-ventilated area out of the reach of children. A disconnected cylinder must have dust caps tightly installed and must not be stored in a building, garage, or any other enclosed area. The minimum permissible gas supply pressure of 11 W.C. is required for the purpose of hose adjustment. The minimum hourly of 1,500 BTU is the required input rating for a heater for automatic operation rating less than full input rating.

The pressure regulator and hose assembly supplied with the appliance must be used.

The installation must conform with local codes, or in the absence of local codes, with national fuel gas code, ANSI Z223.1/NFPA54, natural gas and propane Installation Code, CSA B149.1, or propane storage and handling code, B149.2

A dented, rusted, or damaged propane cylinder may be hazardous and should be checked by your local cylinder supplier. Never use a propane cylinder with a damaged valve connection. The propane cylinder must be constructed and marked in accordance with the specifications for LP gas cylinders of the U.S. Department of Transportation (DOT) or the standard for cylinders, spheres and tubes for transportation of dangerous goods and commission, CAN/CSA-B339.

- Do not store a spare LP-gas cylinder under or near this appliance.
- Never fill the cylinder beyond 80 percent full.
- Place the dust cap on the cylinder valve outlet whenever the cylinder is not in use. Only install the type of dust cap on the cylinder valve that is provided with the cylinder valve. Other types of caps or plugs may result in propane leakage.

- The cylinder must have a listed overfilling prevention device.
- The cylinder must have a connection device compatible with the connection for the appliance.
- The cylinder used must include a collar to protect the cylinder valve.
- Never connect an unregulated propane cylinder to the heater.

# OPERATING INSTRUCTIONS

## LIGHTING

**NOTE:** Ensure that a AA battery is installed behind the igniter button. The anode (+) side of the battery must face out.

**NOTE:** For initial start or after any cylinder change, hold the control knob in for 2 minutes to purge air from all gas lines before proceeding.

1. Turn the control knob to the "OFF" position.
2. Fully open the LPG tank valve.
3. Push in and turn the control knob to PILOT (⚡) position (counterclockwise). While holding in the Control Knob, press the igniter button.
4. Check for the pilot flame through the glass tube. If the pilot does not light, press and turn the Control Knob clockwise to the OFF position. Repeat steps 1-2.
5. Once the pilot flame is lit, turn the Control Knob counterclockwise to LO position.
6. For maximum heat and flame, turn the Control Knob further to the HI position.
7. To turn the heater off, turn the Control Knob clockwise to PILOT position. Then depress the Control Knob and turn clockwise to OFF position. Close the valve on your LPG cylinder when the heater is not in use.

If you experience any ignition problems, please consult the "Troubleshooting" section of this manual.

**CAUTION:** Avoid inhaling fumes emitted from the heater's first use. Both smoke and odor from the burning of oils used in the manufacturing will appear. Both smoke and odor will dissipate after approximately 30 minutes. The heater should NOT produce thick black smoke.

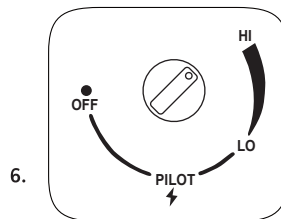
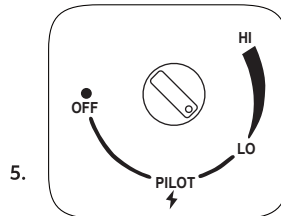
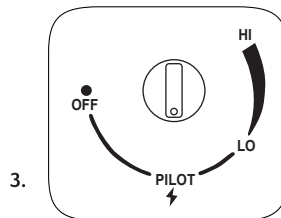
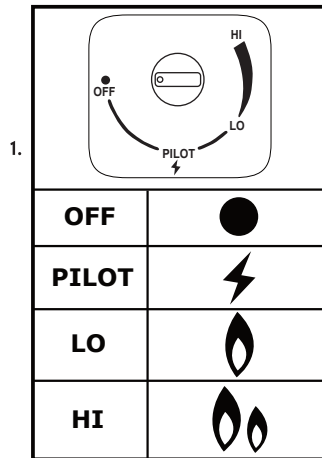

## WARNING

### FOR YOUR SAFETY

Be careful when attempting to manually ignite this heater. Holding in the control knob for more than 10 seconds before igniting the gas will cause a ball of flame upon ignition.

### WHEN HEATER IS ON:

Emitter screen will become bright red due to intense heat. The color is more visible at night. Burner will display tongues of blue and yellow flames. These flames should not produce thick black smoke, indicating an obstruction of airflow through the burners. The flame should be blue with yellow tops. If excessive flame is detected, turn off heater and consult the "Troubleshooting" section of this manual.

### RE-LIGHTING:

**Note:** For your safety, the control knob cannot be turned OFF without first depressing the control knob and then rotating to OFF.

1. Turn control knob to OFF.
2. Wait at least 5 minutes to allow gas to dissipate before re-lighting.
3. Repeat the "Lighting" steps listed above.

# OPERATING INSTRUCTIONS



## OPERATION CHECKLIST:

For a safe and pleasant heating experience, perform this check before each use:

### BEFORE OPERATING:

- I am familiar with entire owner's manual and understand all precautions noted.
- All components are properly assembled, intact and operable.
- No alterations have been made.
- All gas connections are secure and do not leak.
- Wind velocity is below 10 mph.
- Heater is for use outdoors (outside any enclosure).
- There is adequate fresh air ventilation.
- Heater is away from gasoline or other flammable liquids or vapors.
- Heater is away from windows, air intake openings, sprinklers and other water sources.
- Heater is at least 36 in. on top and at least 24 in. on sides from combustible materials.
- Heater is on a hard and level surface.
- There are no signs of spider or insect nests in heater orifices.
- All burner passages are clear.
- All air circulation passages are clear.
- Clothing or other protective material should not be hung from the heater, or placed on or near the heater.
- Any guard or other protective device removed for servicing the heater must be replaced prior to operating the heater.
- Installation and repair should be done by a qualified service person. The heater should be inspected before each use and at least annually by a qualified service person.

### OPERATION INFORMATION AND SAFETY:

- Unit will operate at reduced efficiency below 40°F.
- Alert children and adults to the hazards of high surface temperatures and should stay away to avoid burns or clothing ignition.
- Carefully supervise young children when they are in the area of the heater.
- More frequent cleaning may be required as necessary. It is imperative that control compartment burner and circulating air passageways of the heater be kept clean and free of debris and/or spider or insect nests.



## WARNING

FOR YOUR SAFETY  
Heater will be hot after use. Handle with extreme care.



## SHUT DOWN:

1. Turn control knob clockwise to OFF while depressing the knob. (Normally, burner may make a slight popping noise when extinguished).
2. Turn cylinder valve clockwise to OFF and disconnect regulator when heater is not in use.

**NOTE:** After use, some discoloration of the emitter screen is normal.



## AFTER OPERATION:

1. Gas control knob is in OFF position.
2. Gas tank valve is OFF.
3. Disconnect gas line.
4. Heater is stored upright in a secure location.

# CARE AND MAINTENANCE

To enjoy years of outstanding performance from your heater, make sure you perform the following maintenance activities on a regular basis:

## KEEP EXTERIOR SURFACES CLEAN.

1. Use soapy water for cleaning. Never use flammable or corrosive cleaning agents.
2. While cleaning your unit, be sure to keep the area around the burner and control compartment dry at all times. Do not submerge the control valve assembly. If the gas control is submerged in water, do NOT use it. It must be replaced.
3. Air flow must be unobstructed. Keep controls, burner, and circulating air passageways clean. Signs of possible blockage include:
4. Gas odor with extreme yellow tipping of flame.
5. Heater does NOT reach the desired temperature.
6. Heater glow is excessively uneven.
7. Heater makes popping noise.
8. Spiders and insects can nest in burner or orifices. This dangerous condition can damage heater and render it unsafe for use. Clean burner holes by using a heavy-duty pipe cleaner. Compressed air may help clear away smaller particles.
9. Carbon deposits may create a fire hazard. Clean dome and burner screen with warm soapy water if any carbon deposits develop.

**Note:** *In a salt-air environment (such as near an ocean), corrosion occurs more quickly than normal. Frequently check for corroded areas and repair them promptly.*



### TIP FOR STAINLESS STEEL MODELS:

*Use high-quality automobile wax to help maintain the appearance of your heater. Apply to exterior surfaces from the post down. DO NOT apply to emitter screen or domes.*

## WARNING

### FOR YOUR SAFETY

- Do NOT touch or move heater for at least 45 minutes after use.
- Reflector is hot to the touch.
- Allow reflector to cool before touching.

## STORAGE:

### Between uses:

- Turn control knob OFF.
- Disconnect LP source.
- Store heater upright in an area sheltered from direct contact with inclement weather (such as rain, sleet, hail, snow, dust and debris).
- If desired, cover heater to protect exterior surfaces and to help prevent build-up in air passages. Never leave LPG tank exposed to direct sunlight or excessive heat.

**Note:** Wait until heater is cool before covering.

## SERVICE:

Only a qualified service person should repair gas passages and associated components.

**Caution:** *Always allow heater to cool before attempting service.*

# TROUBLESHOOTING

PROBLEM	POSSIBLE CAUSE	CORRECTIVE ACTION
Main burner will not light	Gas valve may be off	Turn gas valve ON
	Fuel tank may be empty	Refill LPG tank
	Orifice blocked	Clean orifice
	Air in supply system	Purge air from lines. Open gas lines and depress control knob for 2-3 minutes.
	Loose connection	Check all fittings
	Igniter doesn't spark	Check igniter cable connection on back of igniter
	Gas pressure low with valve open full	Replace cylinder or regulator
	New cylinder or 1st ignition	Purge air from lines
	Cylinder valve on, no gas flow	Replace hose/regulator assembly
	Dead igniter battery	Replace battery behind igniter button
Low burner flame	Pressure is low	Replace LPG tank
	Tank is low on fuel	Fill LPG tank
	Gas hose is kinked	Check and straighten or replace
Burner unit	Carbon on reflector and emitter screen	Clean components as needed
	Thick black smoke	Blockage in burner assembly—thoroughly clean burner



## LIMITED WARRANTY

---

### JAY TRENDS SALES LIMITED ONE (1) YEAR WARRANTY

Jay Trends warrants your new outdoor patio heater product will be free from defects in material and workmanship for one (1) year from the date of purchase.

#### Conditions and Limitations

Jay Trends warrants its products against manufacturing defects to the original purchaser only, and is subject to the following conditions and limitations:

This factory warranty is non-transferable and may not be extended what-so-ever by any of our representatives.

The product must be assembled, maintained, and operated in accordance with the printed instructions accompanying it. This limited warranty does not cover damages caused by misuse, lack of maintenance, grease fires, hostile environments, accident, alterations, abuse or neglect and parts installed from other manufacturers will nullify this warranty. Discoloration from chemical cleaners or UV exposure is not covered by this warranty.

Any damages to the product due to weather damage, hail, rough handling, damaging chemicals or cleaners will not be the responsibility of Jay Trends.

This limited warranty does not cover any scratches, dents, painted finishes, corrosion or discoloring by heat, abrasive and chemical cleaners, nor chipping on porcelain enamel parts, nor any components used in the installation of the product.

Should deterioration of parts occur to the degree of non-performance (rusted through or burnt through) within the duration of the warranted coverage, a replacement part will be provided.

The bill of sale or copy will be required when making any warranty claims from Jay Trends.

All parts replaced under the Limited One (1) Year Warranty Policy are subject to a single claim.

Jay Trends will not be responsible for the installation, labor, or any other costs related to the re-installation of a warranted part, and such expenses are not covered by this warranty.

Jay Trends reserves the right to have its representative inspect any product or part prior to honoring any warranty claim.

Jay Trends shall not be liable for any transportation charges, labor costs, or export duties.

#### Replacement Parts

In the event that an item was received missing parts or damaged, either by the manufacturer or in shipping, you may request a replacement part. Replacement parts are not available for all units and only given at Jay Trends' discretion. We will assess any damage and find a solution, which could include ordering and shipping a replacement to you. No replacements are available for discontinued items or repackaged (open box) products. Please call Jay Trends Customer Service at 1-877-387-3639 for replacement parts before returning the damaged item. Please have the following information, which can be found in your instruction manual, ready before you call Customer Service.

1. Model Number or Item # \_\_\_\_\_ .
2. Serial # \_\_\_\_\_ & Part # \_\_\_\_\_ .
3. Shipping Address \_\_\_\_\_ .
4. A picture of the damaged item/part/unit.
5. Pictures should be sent to [custserv@jaytrends.com](mailto:custserv@jaytrends.com).
6. Proof of purchase with date \_\_\_\_\_ .
7. All claims must be received within 30 days of receipt of order.

Jay Trends Sales  
1901 Aut. Transcanadienne  
Dorval, QC H9P 1J1, Canada  
[www.jaytrends.com](http://www.jaytrends.com)

Customer Service: 1-877-387-3639 in USA & Canada  
[custserv@jaytrends.com](mailto:custserv@jaytrends.com)